



# TAPER BOLT®

TESTED OR APPROVED BY:

## THE ORIGINAL. THE STRONGEST. THE MOST VERSATILE.

A true parallel expansion design incorporating SAE torque specifications and clamp loads. All the attributes of a standard Grade 5 bolt including the convenience of installation with high speed impact tools.

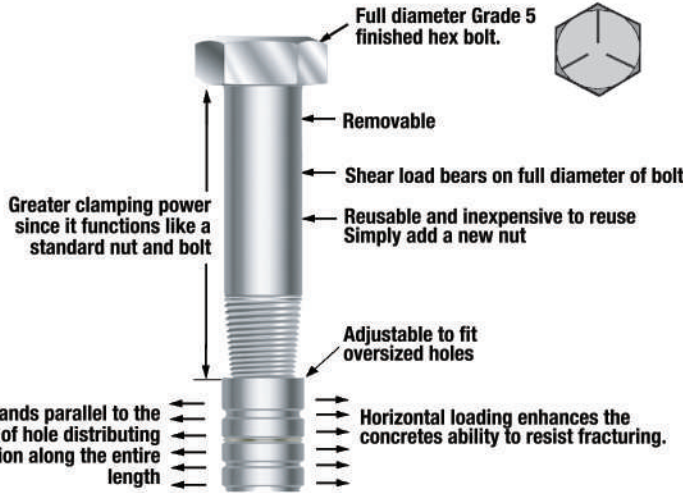
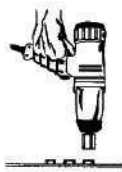

- Pittsburgh Testing Laboratory PG-2170
- City of New York
- City of San Francisco
- Many State D.O.T.'s
- Federal General Services - Exceeds G.S.A. FF-S-325
- Meets O.S.H.A. requirement of Sec. No. 1910.212(b)
- Produced under quality assurance programs in accordance with 10 CFR 50 Appendix b
- and N.R.C Requirements

## RECOMMENDED APPLICATIONS:

- Temporary Highway Barriers
- Highway Guide Rail
- Highway Expansion Joints
- Railroad Rail Track
- Plate Fastening
- Tilt Wall Temporary
- Safety Cable Tie-Off
- Rapid Runway Repair
- Lift Points

### Test Data 1/2" @ 2-3/8" Embedment

Unreinforced 3000 P.S.I. Concrete  
Tension - 8,165 lbs  
Shear - 12,177 lbs

Unreinforced 5000 P.S.I. Concrete  
Tension - 9,346 lbs  
Shear - 15,217 lbs

### MATERIAL SPECIFICATIONS:

**BOLTS:**  
S.A.E. Grade 5 Heat Treated Steel  
Hardness - RC 25/34  
Proof Load - 85,000 P.S.I.  
Tensile Strength - 120,000 P.S.I.  
Zinc Plated to A.S.T.M. B-633

**EXPANDER NUT:**  
S.A.E. 903 A.S.T.M. B86  
Die cast Zamak No. 3  
Zinc Alloy  
Tensile Strength 43,000 P.S.I.



[MKTfasteningUSA.com](http://MKTfasteningUSA.com)

MKT Fastening, LLC

800-336-1640

[info@MKTfasteningUSA.com](mailto:info@MKTfasteningUSA.com)

1 Gunnebo Drive · Lonoke, AR 72086

# THE ORIGINAL. THE STRONGEST. THE MOST VERSATILE.

A true parallel expansion design incorporating SAE torque specifications and clamp loads. All the attributes of a standard Grade 5 bolt including the convenience of installation with high speed impact tools.



**Taper Bolt can be removed as often as necessary.**

**Taper Bolt can be used in a new hole many times, no limitation.**

**Taper Bolt can be adjusted to fit oversize holes!**

**Taper Bolt offers 10% greater tensile strength and 50% greater shear strength.**

**Taper Bolt is manufactured from a certified full diameter Grade 5 steel bolt, not a rolled up piece of wire.**



## Taper Bolt

## Standard Bolt

### Test Data 1/2" @ 2-3/8" Embedment

Unreinforced 3000 P.S.I. Concrete  
Tension - 8,165 lbs  
Shear - 12,177 lbs

Unreinforced 5000 P.S.I. Concrete  
Tension - 9,346 lbs  
Shear - 15,217 lbs

### Test Data 1/2" @ 2-1/2" Embedment

Unreinforced 3000 P.S.I. Concrete  
Tension - 7,682 lbs  
Shear - 7,847 lbs

Unreinforced 5000 P.S.I. Concrete  
Tension - 8,643 lbs  
Shear - 9,795 lbs

### MATERIAL SPECIFICATIONS:

**BOLTS:**  
S.A.E. Grade 5 Heat Treated Steel  
Hardness - RC 25/34  
Proof Load - 85,000 P.S.I.  
Tensile Strength - 120,000 P.S.I.  
Zinc Plated to A.S.T.M. B-633

**EXPANDER NUT:**  
S.A.E. 903 A.S.T.M. B86  
Die cast Zamak No. 3  
Zinc Alloy  
Tensile Strength 43,000 P.S.I.

### MATERIAL SPECIFICATIONS:

Case Hardened Carbon Steel  
Zinc Plated to A.S.T.M. B-633



**MKTfasteningUSA.com**

MKT Fastening, LLC

800-336-1640

info@MKTfasteningUSA.com

1 Gunnebo Drive · Lonoke, AR 72086

**Taper Bolt has demonstrated over 50 years of versatility and reliability.**